

ALFER CONNECTOR WOOD-CONCRETE

STANDARD PRODUCT SHEET

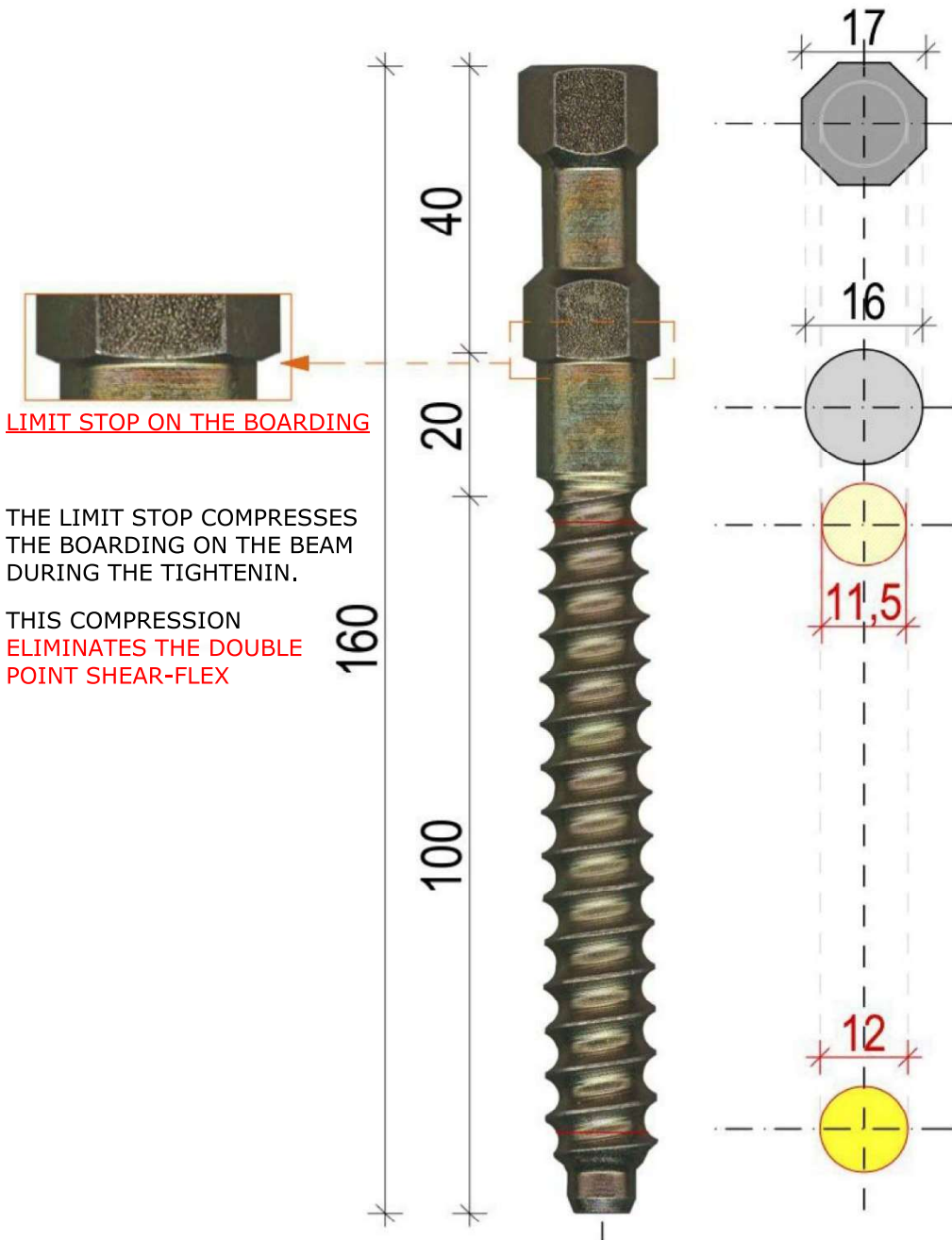

AREA OF APPLICATION

STATIC RECOVERY:

- A) TIMBER FLOORS
- B) HOLLOW BRICKS SLABS

NEW BUILDINGS:

- C) TIMBER-CONCRETE COMPOSITE FLOORS

INSTALLATION STEPS

EQUIPMENT

1) TRACING

- CHALK LINE TRACER



2) DRILLING

- Ø11.5 DRILL BIT FOR METAL/WOOD



- DRILLING MACHINE



3) TIGHTENING

- 17 MM IMPACT SOCKET



- POWER IMPACT WRENCH MIN 280N

